

# COWBOY ROCKETWORKS

OKLAHOMA STATE UNIVERSITY

## AIAA HIGH-POWER ROCKETRY TEAM



### TORY II

**COMPETITION:** 2017 SPACEPORT AMERICA CUP

**CATEGORY:** 10K COTS - ALL PROPULSION TYPES

#### SPECIFICATIONS:

- MOTOR: AEROTECH M1500G
- HEIGHT: 127"
- DIAMETER: 4"
- WEIGHT: 37.1 LB

#### FEATURES:

- COMPLETE FIBERGLASS STRUCTURE
- PID-CONTROLLED AIRBRAKE
- AUTONOMOUS UAV PAYLOAD

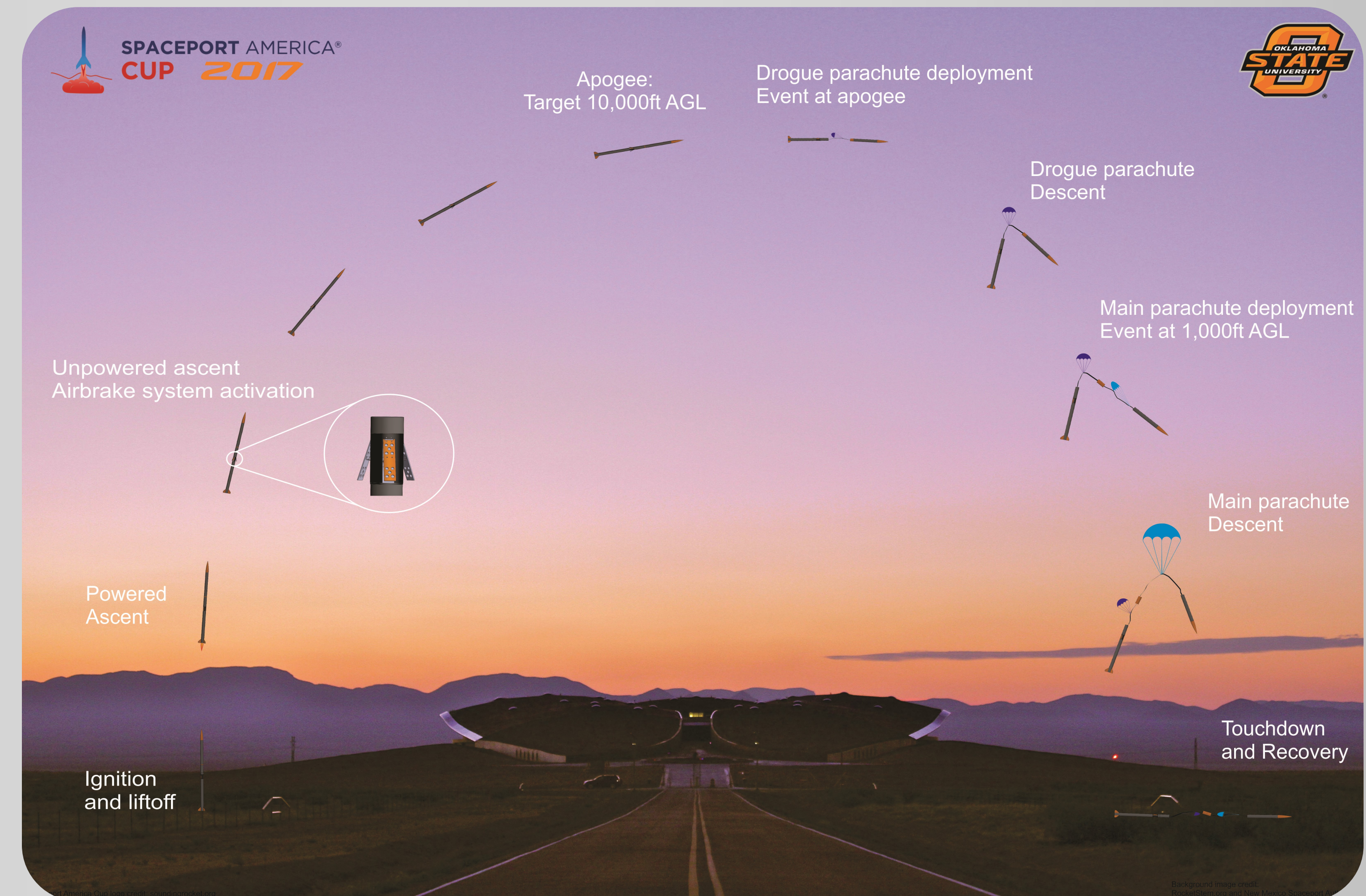

### CONOPS

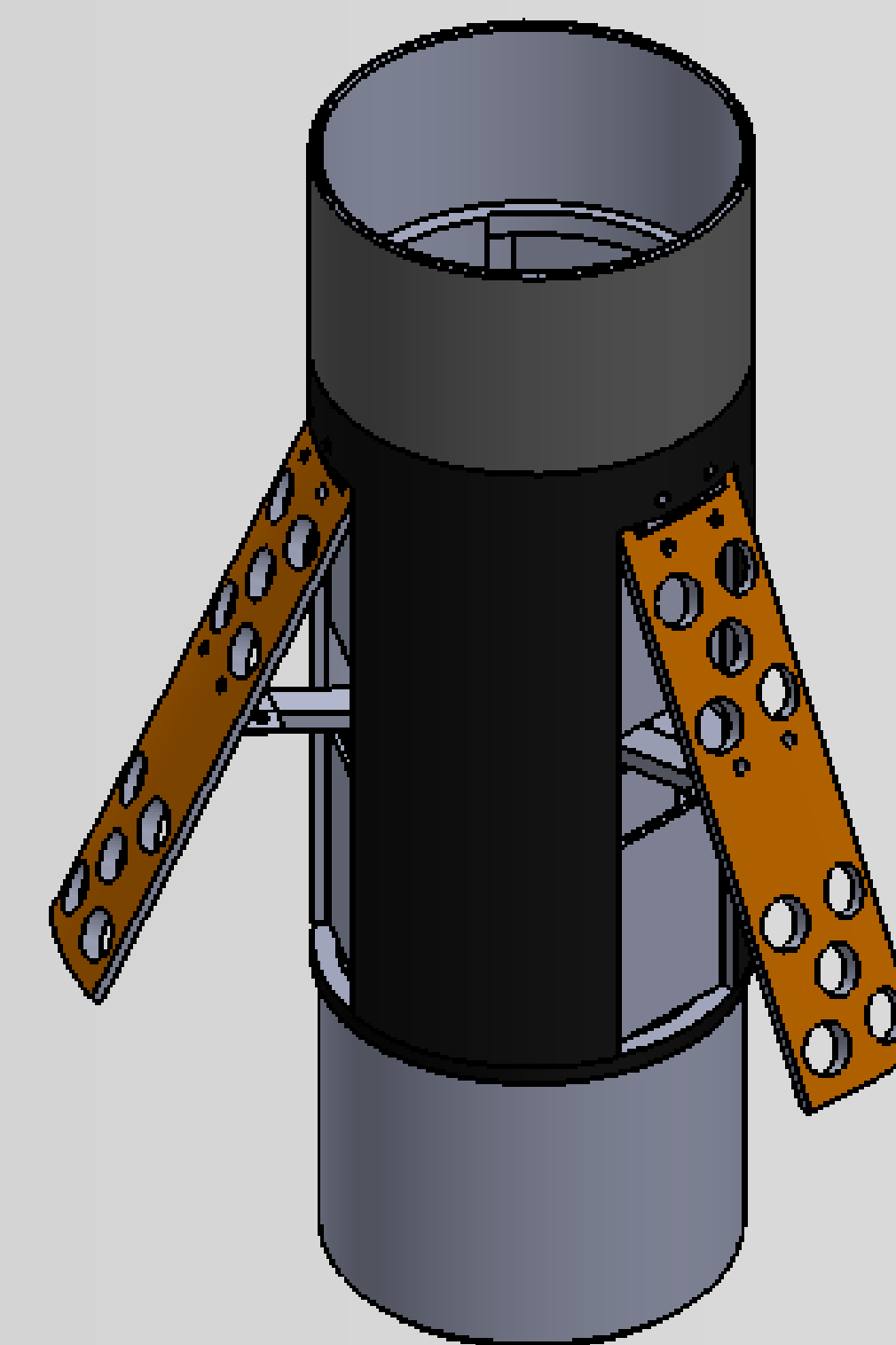
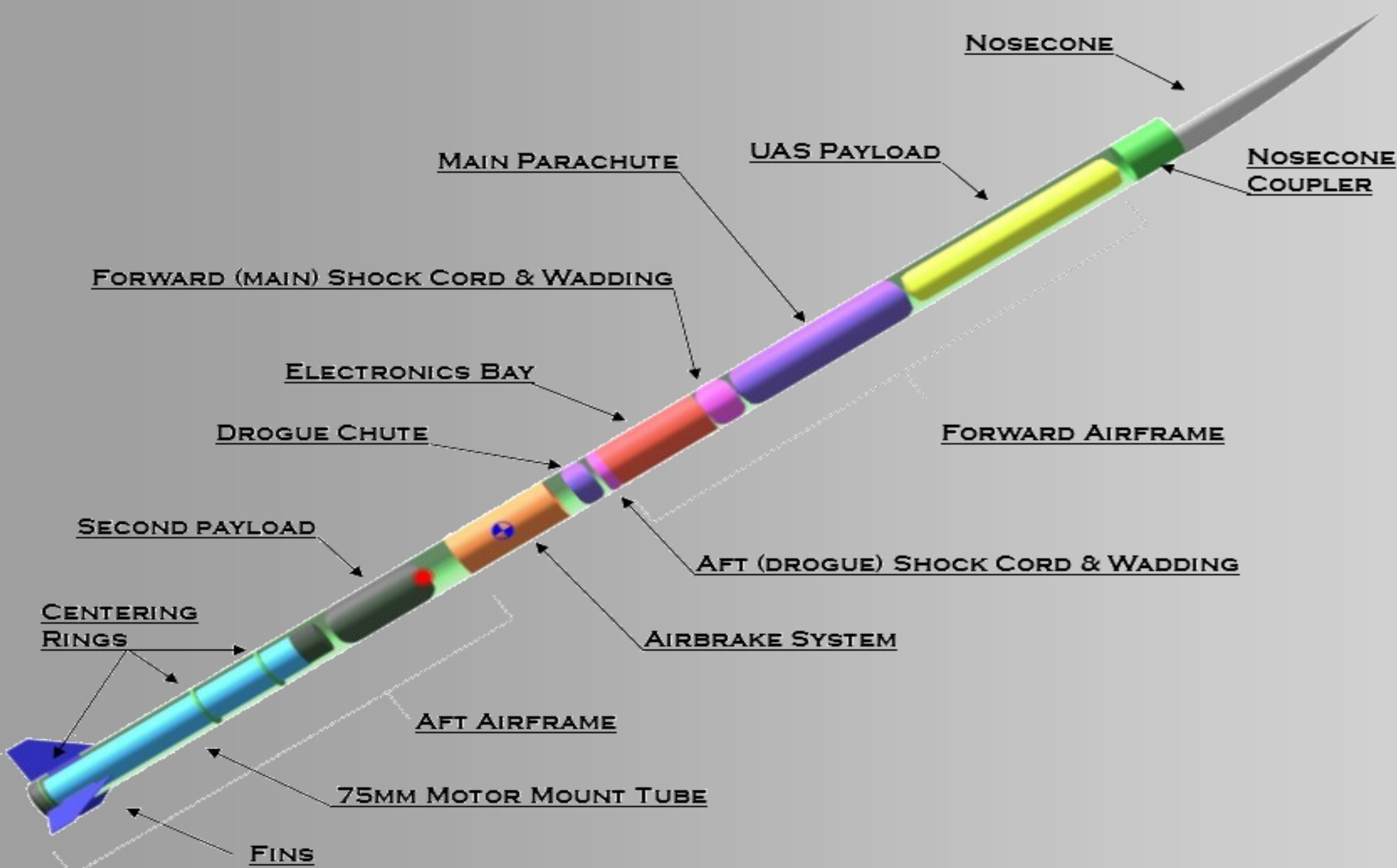

Modular Airbrake

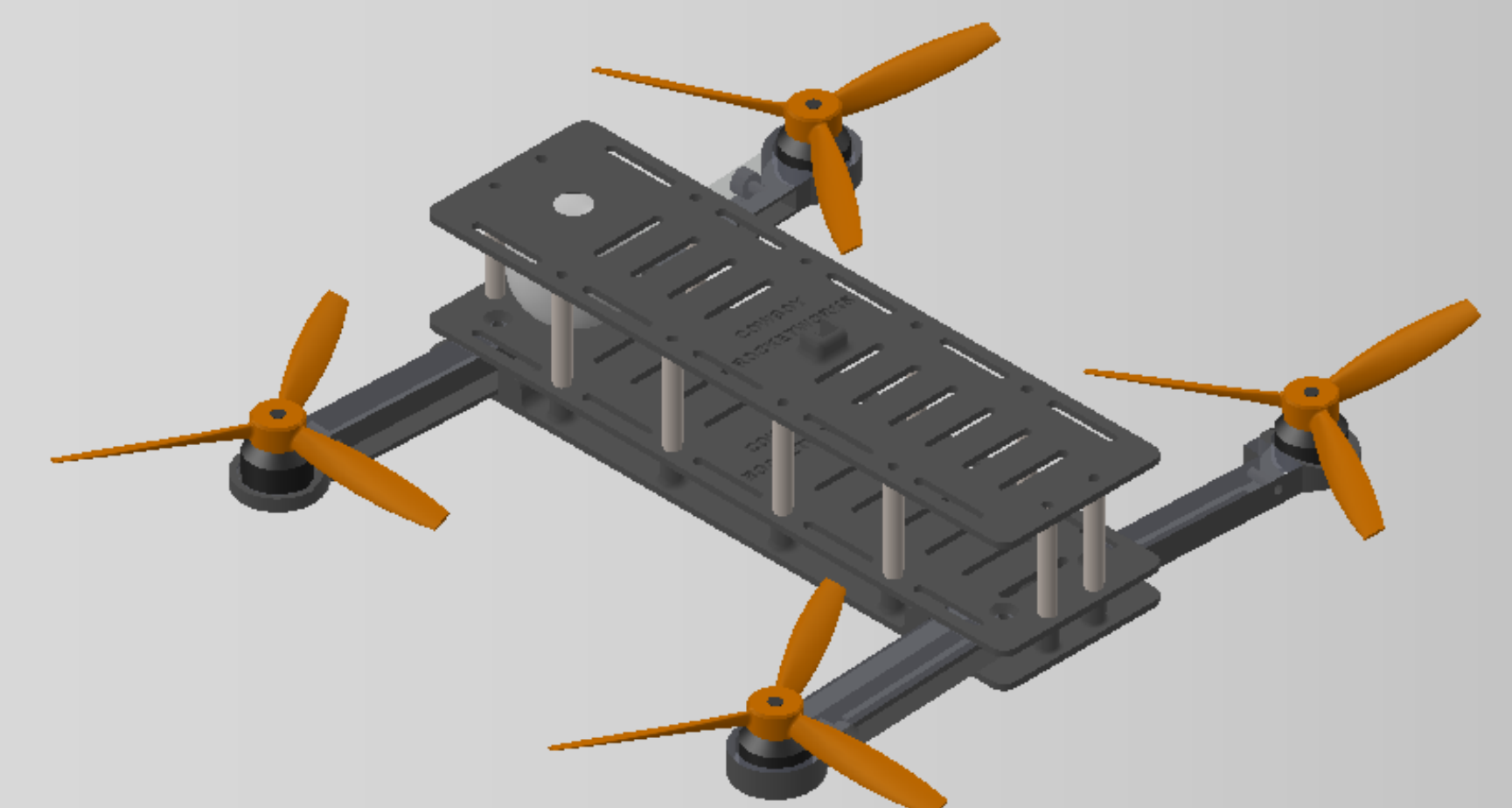

Autonomous UAV Payload

